

SAMPLE QUESTIONS



A: NUMBER

Spreadsheets

Knowledge

Use the following chart to answer question 1.

I.	Highlight cells A1 to A3
II.	Choose cells
III.	Choose format option
IV.	Choose font

1. To change the font in cells A1, A2 and A3, what is the correct order for the steps shown above?

- * A. I, III, II, IV
B. II, IV, I, III
C. III, II, I, IV
D. IV, III, II, I

Understanding

Use the following table to answer question 2.

		A	B	C	D
1		wins	losses	ties	points
2	Birds				
3	Strikers				
Win = 2 points; Tie = 1 point; Loss = 0 points					

2. The Birds have 3 wins, 4 ties and 0 losses. The Strikers have 4 wins, 2 ties and 1 loss. Choose a formula to find the Birds' points.

- A. = B3 + C3
B. = A2 + C2
* C. = A2 * 2 + C2
D. = A3 * 2 + B2

Higher Mental Processes

Use the following spreadsheet to answer question 3.

	A	B	C	D	E	F	G	H	I	J
1	Item	Price (\$)	Quantity		Total (\$)					
2	T-shirt	15.99	20		319.80					
3	Shorts	23.99	10		239.90					
4	Socks	6.99	30							
5				Subtotal						
6				GST						
7				PST						
8				Total	877.12					

3. In which province were these items purchased?

- A. Ontario
- B. Manitoba
- C. Nova Scotia
- D. British Columbia

*

Personal Banking

Knowledge

4. What is the length of time before a cheque becomes “stale”?
- A. 1 month
 - * B. 6 months
 - C. 5 years
 - D. Cheques do not go “stale.”

Understanding

5. Suzie has a Self-Serve Account and has selected a monthly statement with no cheque returns. In September she wrote 12 cheques, paid 5 bills by phone and used her ATM 7 times. What were her service charges for the month of September if she maintains a monthly balance of less than \$1500.00?

Answer

10.95

Higher Mental Processes

Use the following table to answer question 6.

Account type	Monthly fee	Cheque fee	Bill payment	ATM
Value	\$2.95	<ul style="list-style-type: none">• 1st 15 cheques free• Then \$1.00/cheque	<ul style="list-style-type: none">• Bills free	<ul style="list-style-type: none">• 1st 10 free• Then \$1.50/transaction
Self-Serve	\$6.95	<ul style="list-style-type: none">• 1st 10 cheques free• Then \$2.00/cheque	<ul style="list-style-type: none">• First 2 bills free• Then \$0.50 each	<ul style="list-style-type: none">• All free
Full-Serve	\$9.95	<ul style="list-style-type: none">• 1st 30 cheques free• Then \$2.00/cheque	<ul style="list-style-type: none">• Bills free	<ul style="list-style-type: none">• 1st 5 free• Then \$1.50/transaction
Savings	No fee	<ul style="list-style-type: none">• No cheques	<ul style="list-style-type: none">• \$2.00 each	<ul style="list-style-type: none">• No ATM

6. George is trying to choose a bank account. He writes 26 cheques, makes 3 deposits, pays 4 bills by telephone and withdraws cash from an ATM 7 times a month. Which is the best account for him?
- A. Value Account
 - B. Savings Account
 - C. Self-Serve Account
 - * D. Full-Serve Account

Wages, Salaries & Expenses

Knowledge

7. Which table is used to find deductions regardless of the length of the pay period?
- A. Federal Tax (Federal Tax)
 - * B. EI (Employment Insurance)
 - C. CPP (Canada Pension Plan)
 - D. Provincial Tax (British Columbia Provincial Tax)

Understanding

Prescribed Learning Outcomes – A13

8. Cheri earns \$10/h and works a 40-hour week. What is Cheri's Federal Tax deduction if her Claim Code is 1?

Answer

36.15

Higher Mental Processes

Prescribed Learning Outcomes – A13

12. Part-time employee Charlie states, "Working overtime is pointless—the government taxes it all away anyway." Which of the following strategies could best verify his statement?
- A. Check the net pay of someone who works overtime.
 - B. Multiply Charlie's tax deduction by 1.5 to find overtime tax.
 - * C. Use deduction tables to find the effect of higher income on taxes deducted.
 - D. Compare Charlie's gross pay when he worked overtime with when he didn't work overtime.

B: PATTERNS AND RELATIONS

Rates, Ratio and Proportion

Knowledge

10. A supermarket sells natural spring water at \$3.69 for 12 bottles. Which of the following will calculate the unit price of 1 bottle of water in dollars?
- A. 12 divided by 369
 - B. 369 divided by 12
 - C. 12 divided by 3.69
 - * D. 3.69 divided by 12

Understanding

11. Orange juice comes in 2 sizes. The smaller size sells at 89¢ for 375 mL, while the larger size sells at \$1.09 for 500 mL. Which is a better buy, and by how much?
- A. smaller size by 0.02¢/mL
 - * B. larger size by 0.02¢/mL
 - C. larger size by 0.38¢/mL
 - D. they both cost the same

Use the following table to answer question 12.

At a department store, socks sell according to the following table:

Quantity	Price
1 package of 1 pair	\$2.99
1 package of 2 pairs	\$5.50
1 package of 3 pairs	\$7.99

12. Jane wants to buy 7 pairs of socks. Which combination of packages is the least expensive?

Record your answer neatly on the response form as a 3-digit number.

- 1st digit represents the number of packages of one pair
- 2nd digit represents the number of packages of two pairs
- 3rd digit represents the number of packages of three pairs

Answer

102

Trigonometry

Knowledge

Use the following diagram to answer question 14.

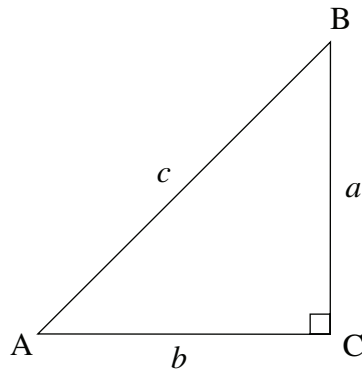

14. What is $\sin A$?

A. $\frac{b}{c}$

B. $\frac{a}{b}$

* C. $\frac{a}{c}$

D. $\frac{b}{a}$

Understanding

Use the following diagrams to answer question 15.

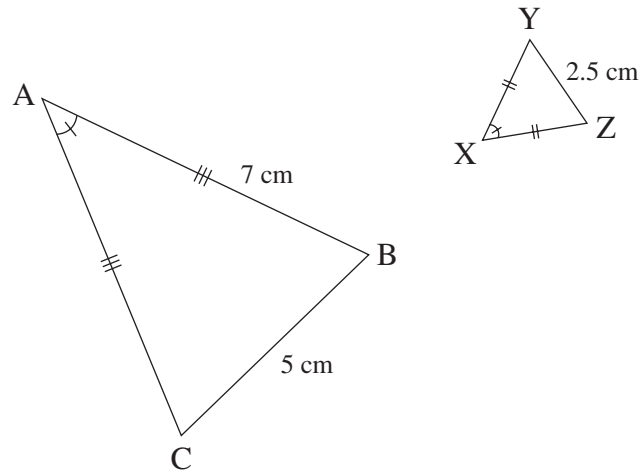

15. What is the length of side XZ ?

Answer

3.5

Geometry Project

Knowledge

16. What is the missing dimension x ?

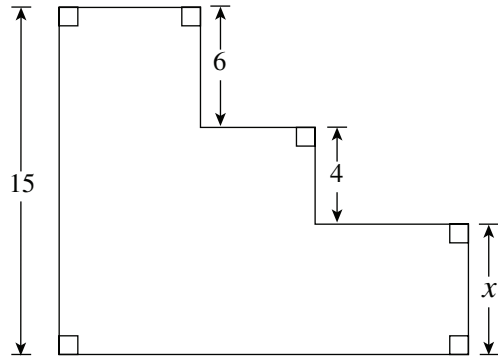

- * A. 4
B. 5
C. 6
D. 10

Understanding

17. A map of the schoolyard uses a scale of 1 cm : 8 m. If the length of the building is 144 m, how long is the drawing of the building on the map?

- * A. 8 cm
B. 18 cm
C. 8 m
D. 18 m

Higher Mental Processes

18. A contractor takes a rectangular floor plan as shown in the diagram and makes a mistake in applying the scale factor.

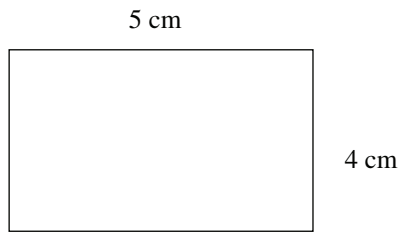

Scale 1 cm : 4 m

He ends up making the actual floor 16 m by 25 m. By what percent did the area of the actual floor turn out to be too big?

- A. 20%
- * B. 25%
- C. 80%
- D. 125%

D: STATISTICS AND PROBABILITY

Probability and Sampling

Knowledge

19. On a Math quiz, the marks for 10 students were:

6, 7, 9, 2, 6, 10, 8, 3, 9, 6

What is the mode?

- *
A. 6
B. 6.5
C. 6.6
D. 7

Understanding

20. Sixteen out of 20 students surveyed at Smithsonian High indicated that they did not want school uniforms. Based on this survey, if the school population is 1200, how many are likely to say they do not want school uniforms?

Answer

960

Use the following table to answer question 21.

(The data in the table was obtained using the capture-mark-recapture method.)

	Wolf Population	Caribou Population
Week 1	Initial number captured and marked = 75	Initial number captured and marked = 62
Week 2	Total number captured = 150 Marked number captured = 35	Total number captured = 120 Marked number captured = 20

21. Which herd has a higher population and by how much?

- A. There are 51 more wolves than caribou.
- * B. There are 51 more caribou than wolves.
- C. Both populations are equal.
- D. Not enough information.